

Tug Pushing Ahead. Length of tow < 200 meters. Over 200 meters (3) White Masthead Lights. Special flashing yellow light @ centerline of barge; flashes 50-70 times/minute. **Mnemonic, Yellow, Yellow Pushy Fellow**

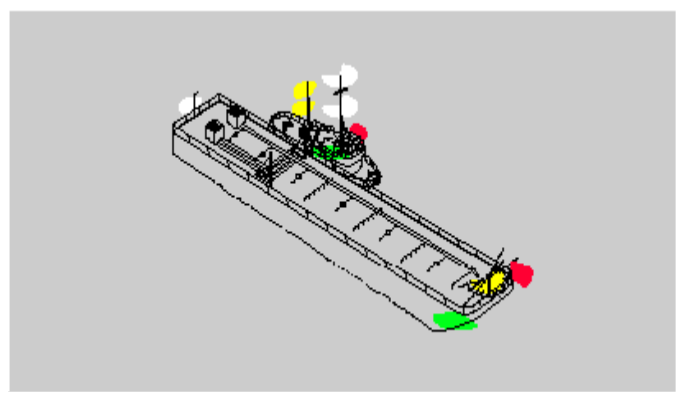

Tug Pushing Ahead on Hip. Length of tow < 200 meters. Over 200 meters (3) White Masthead Lights. Special flashing yellow light @ centerline of barge; flashes 50-70 times/minute. **Mnemonic, Yellow, Yellow Pushy Fellow**

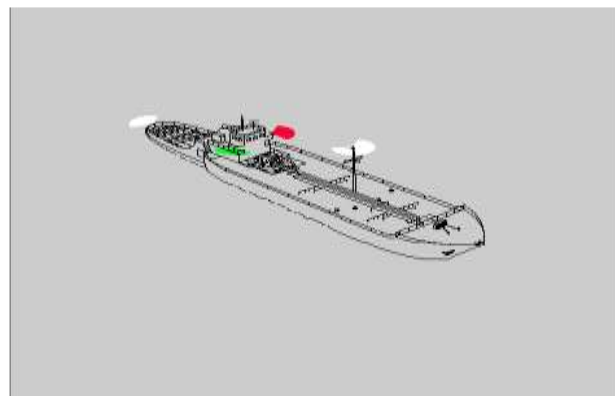

Composite unit < 50 meters, tug and barge rigidly connected has same light configuration as a Power Vessel

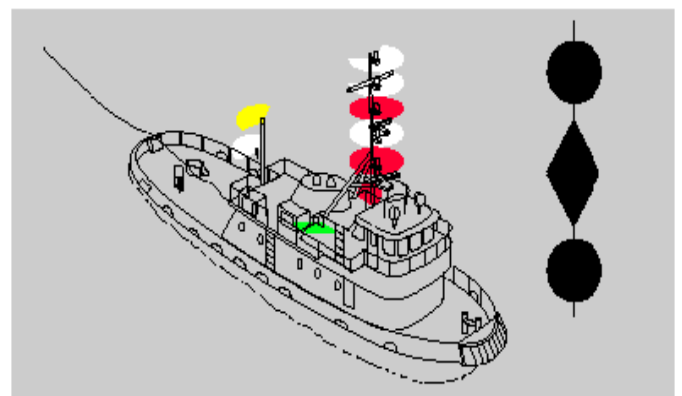

Vessel engaged in towing operation which severely restricts towing vessel and her tow in their ability to deviate from their course. Length of tow < 200 meters and towing vessel < 50 meters in length

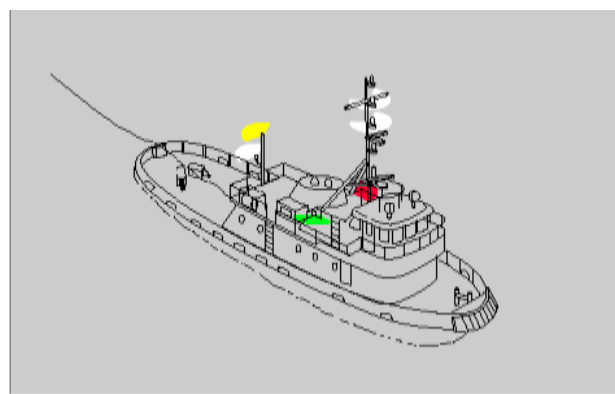

Stern tow < 200 meters. **Mnemonic, Two in a row something in tow**

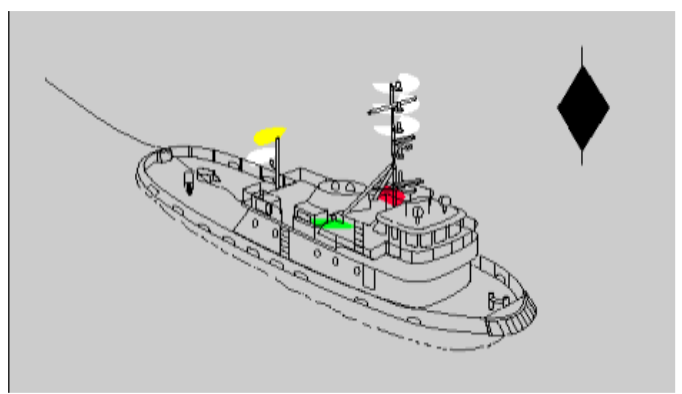

Stern tow > 200 meters. **Mnemonic, Three in a row very long tow**

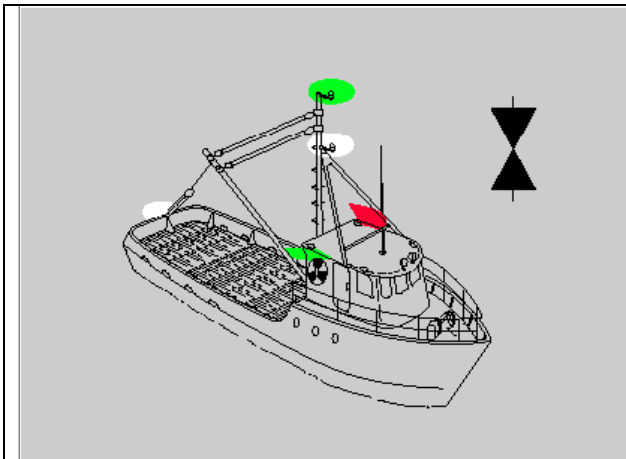

Trawler Making Way. Vessel < 50 meters in length. **Mnemonic, Green over White Trawling Tonight**

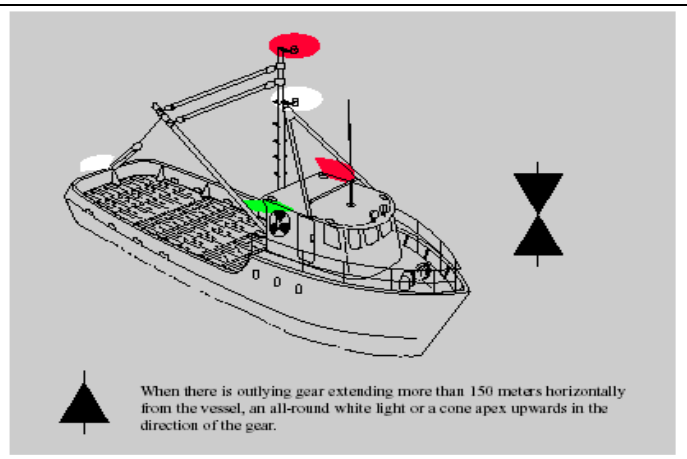

Vessel engaged in Fishing, other than Trawling, Making Way. **Mnemonic, Red over White Fishing Tonight**

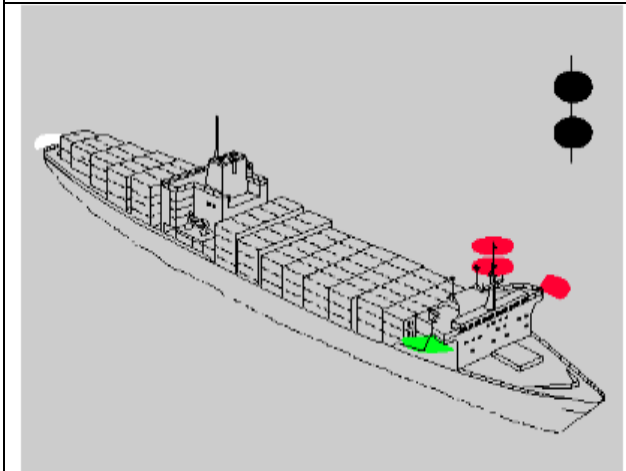

Vessel Not Under Command & Making Way

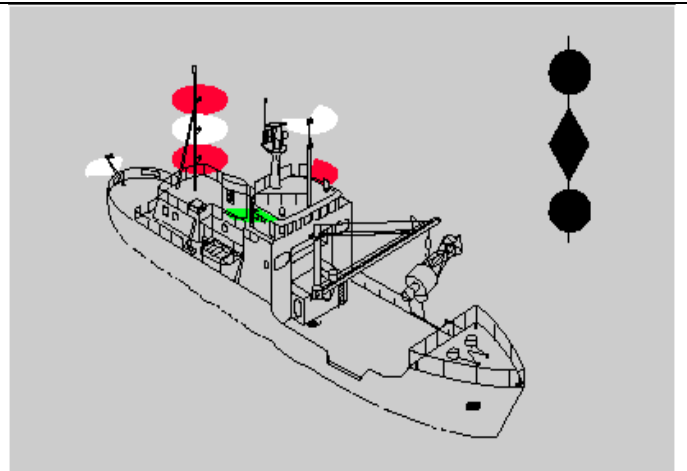

Vessel restricted in her ability to maneuver & Making Way. Vessel < 50 meters in length.

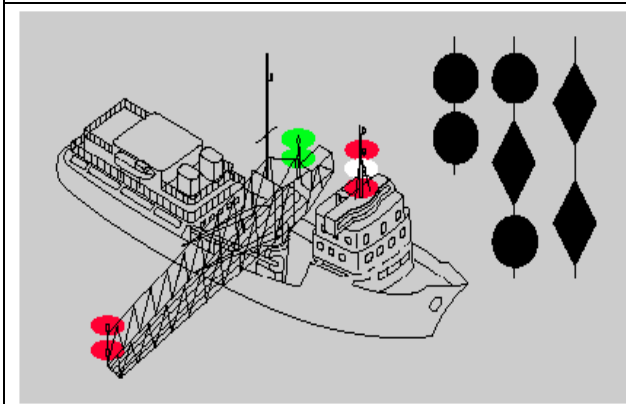

Vessel engaged in dredging or underwater operations when restricted in ability to maneuver & not making way. **Mnemonic, Diamonds are a girl's best friend; don't bust your Balls between the ship and the shore.**

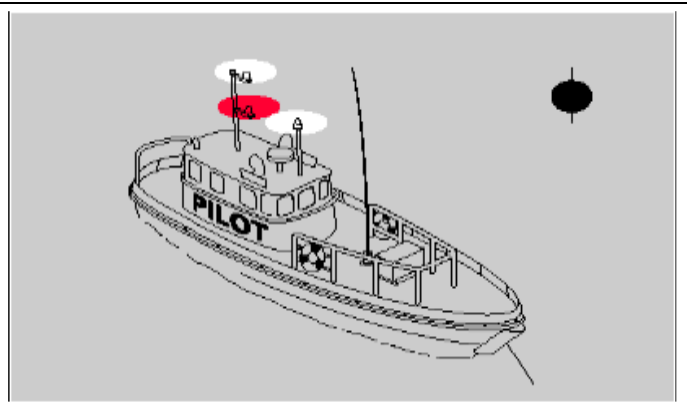

Pilot Vessel. **Mnemonic, White over Red Pilot in Bed**